

3d Scanning for Civil applications

Scanning has lent itself to numerous applications in the civil field. From simple detail and road surveys to structural elements such as bridges and foundations.

The process of scanning has lent itself to the civil field with safety being one of the main attractions. Time in the field is reduced and contact with the areas of interest are minimised. The surveyor doesn't have to enter the carriageway to acquire 5mm contours on a road pavement. Measurements of disasters sites can be made without entering the disaster zone.

The quality of capture is also enhanced. Greater confidence in the data is also found by the client using scan capture.



Road Infrastructure

All line marking, above ground services and signage are captured in the scan data

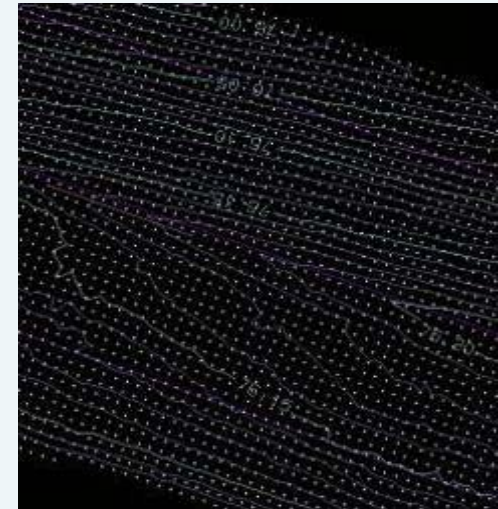
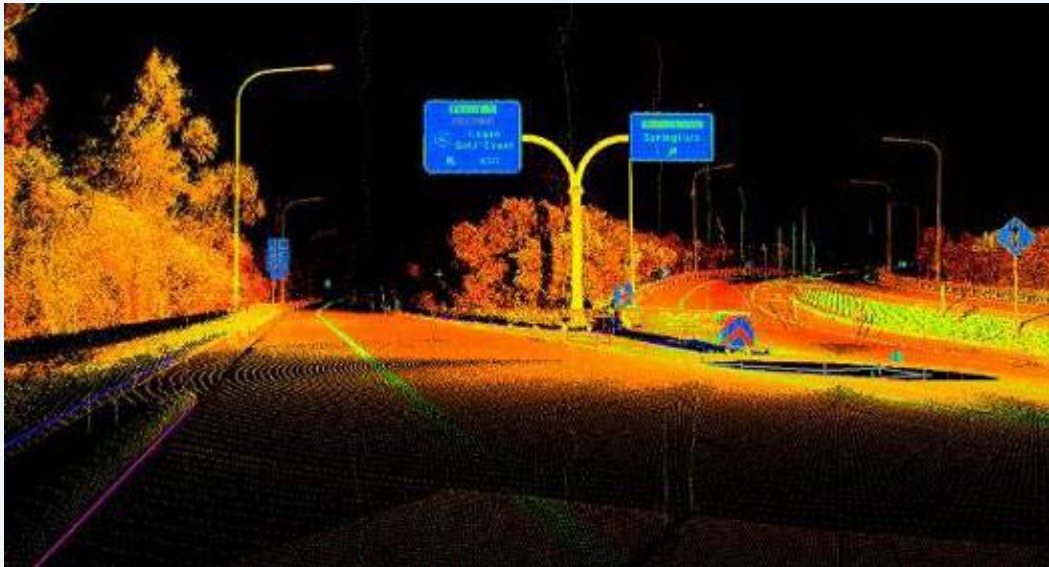

Aquapanning studies – 10mm or better contours extractable

Bridges

SE Freeway archive of damage to structure

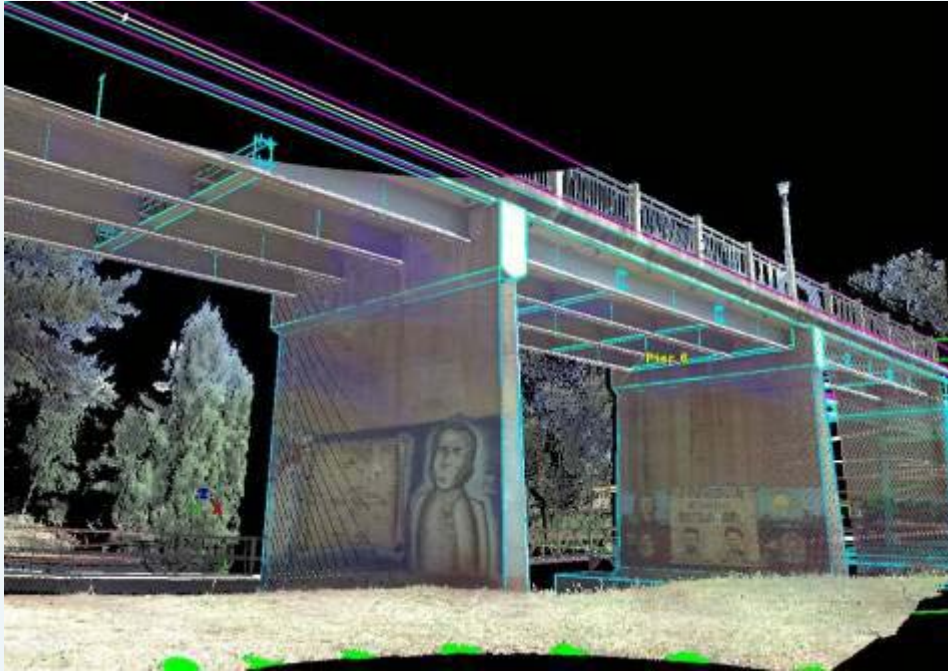

As constructed survey for widening and duplication



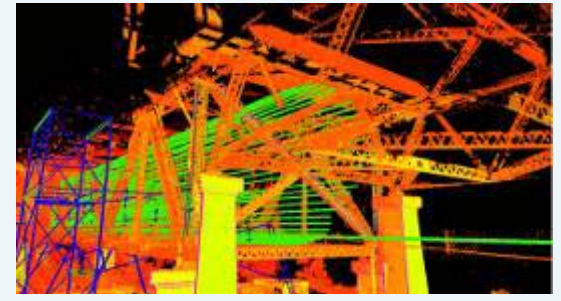
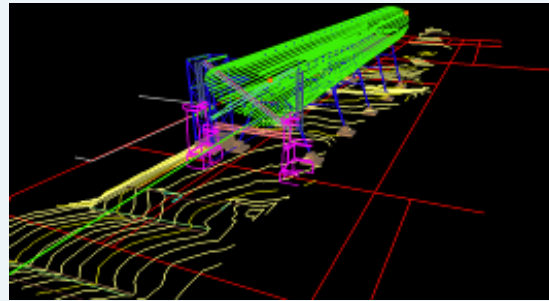
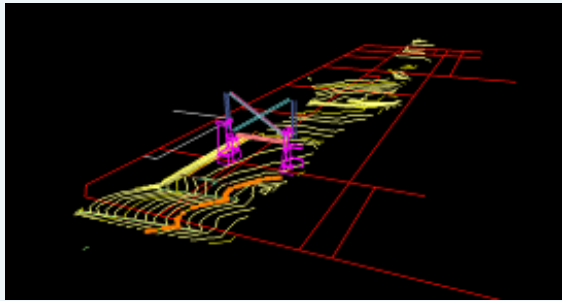

Story Bridge

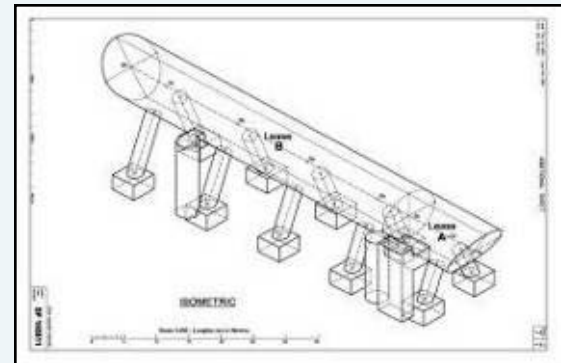
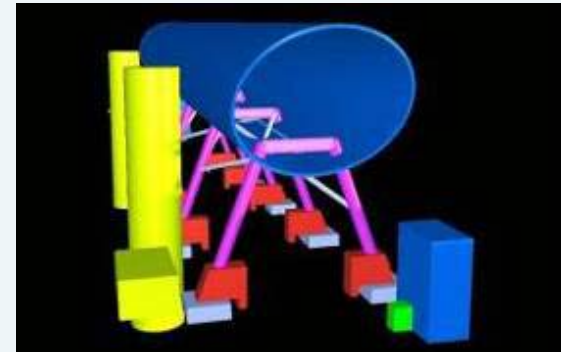
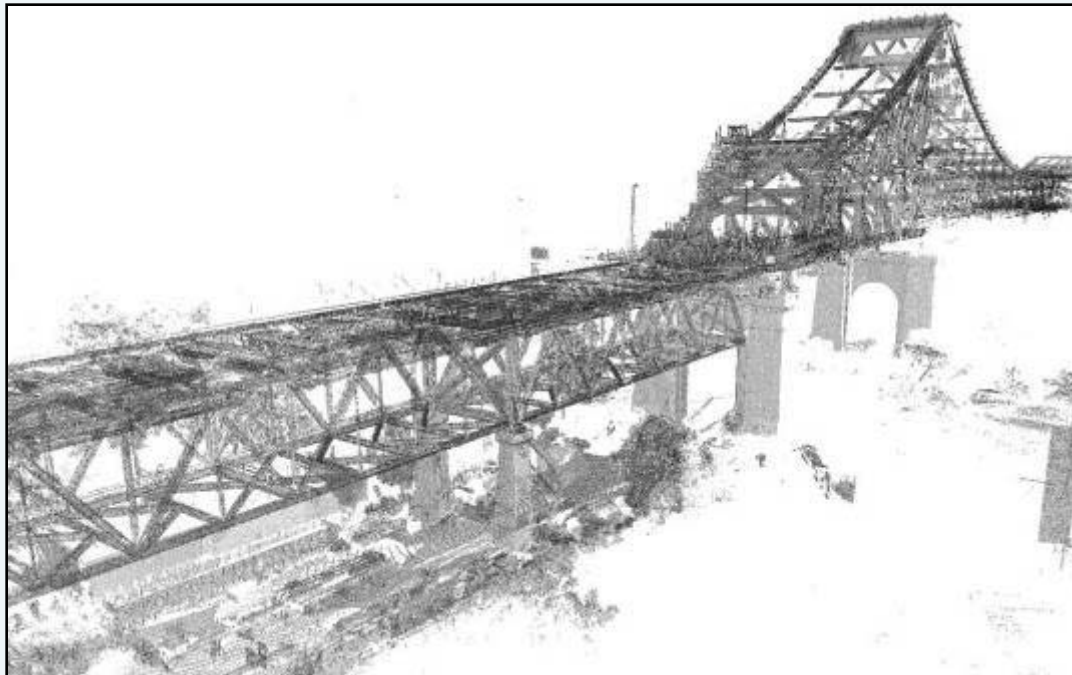

Preparation of lease plan from model – volumetric title survey

Rail Infrastructure

Accurate data captured without
having to access rail

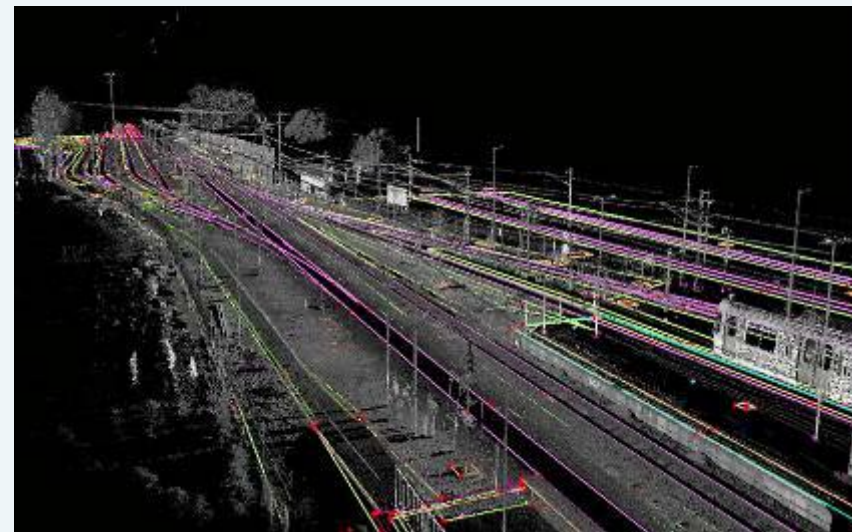
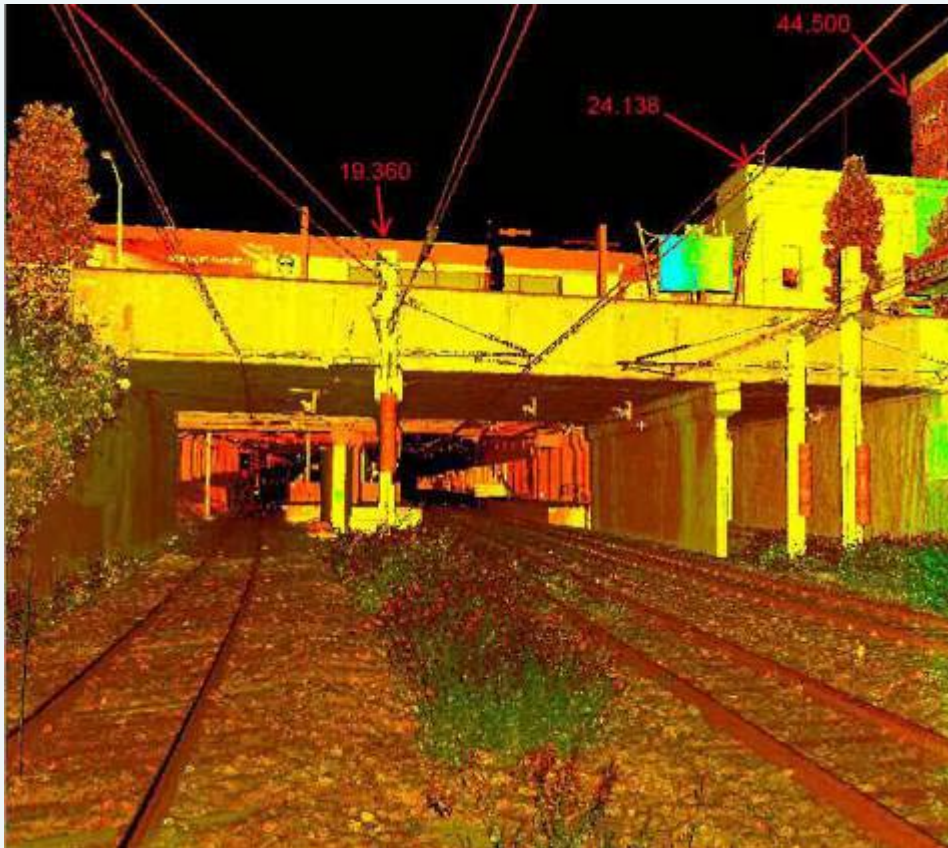

Tunnels

Inside of a tunnel
from the outside!!!

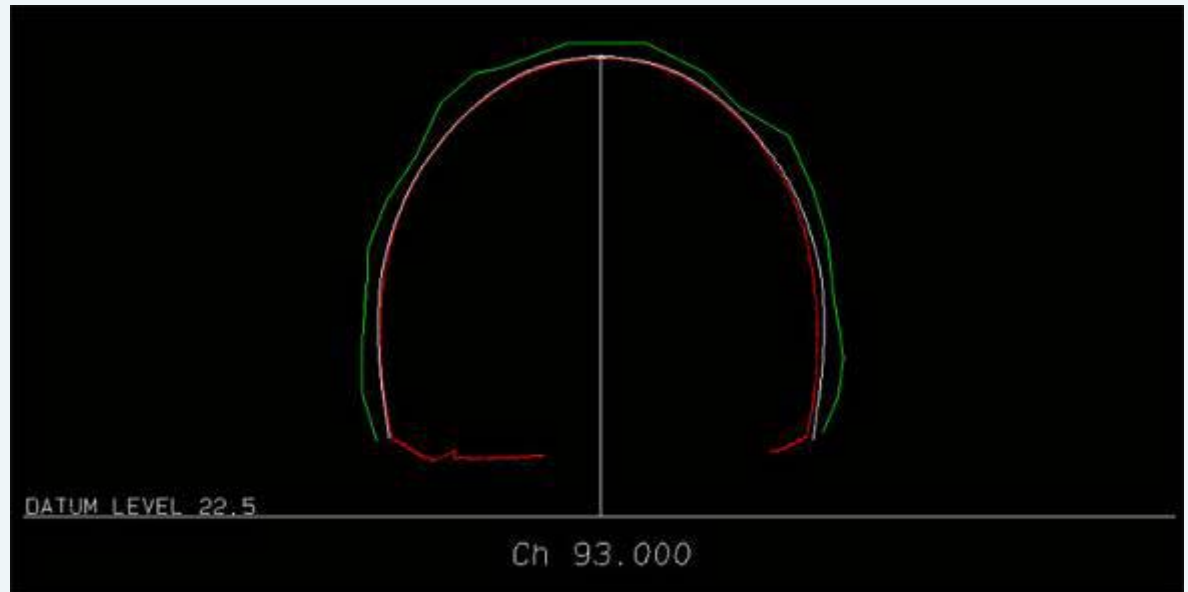

Overlays of original and design

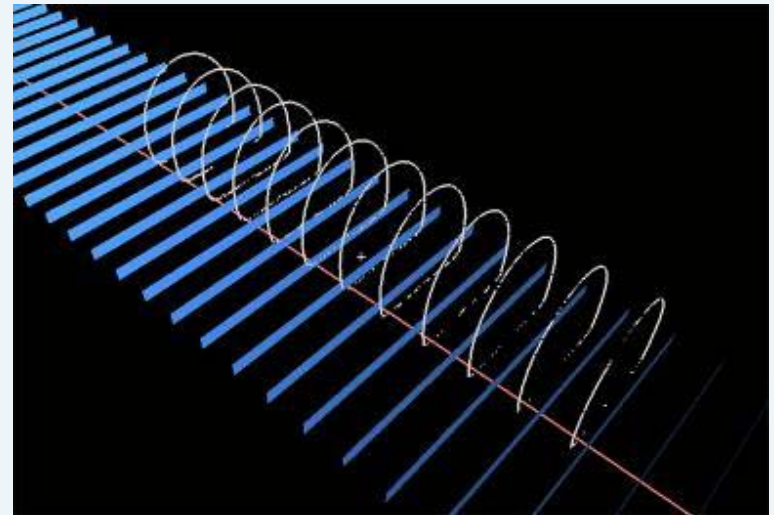
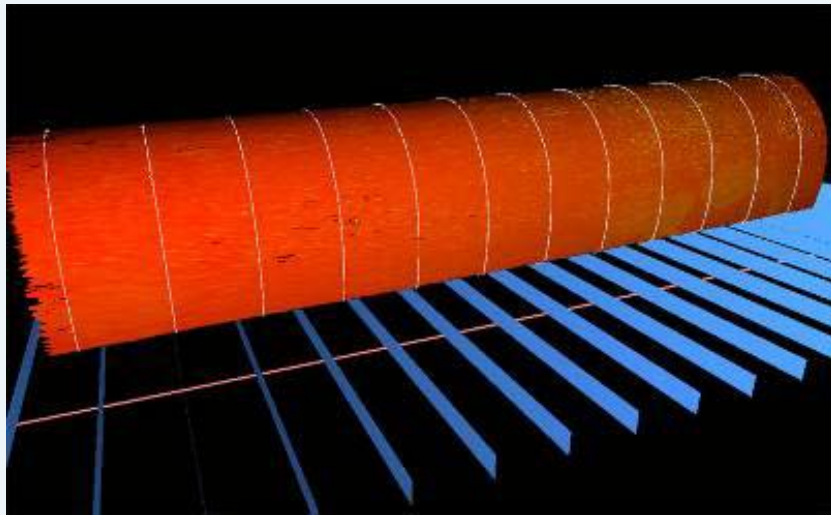

Sections extracted

Rapid as Constructed

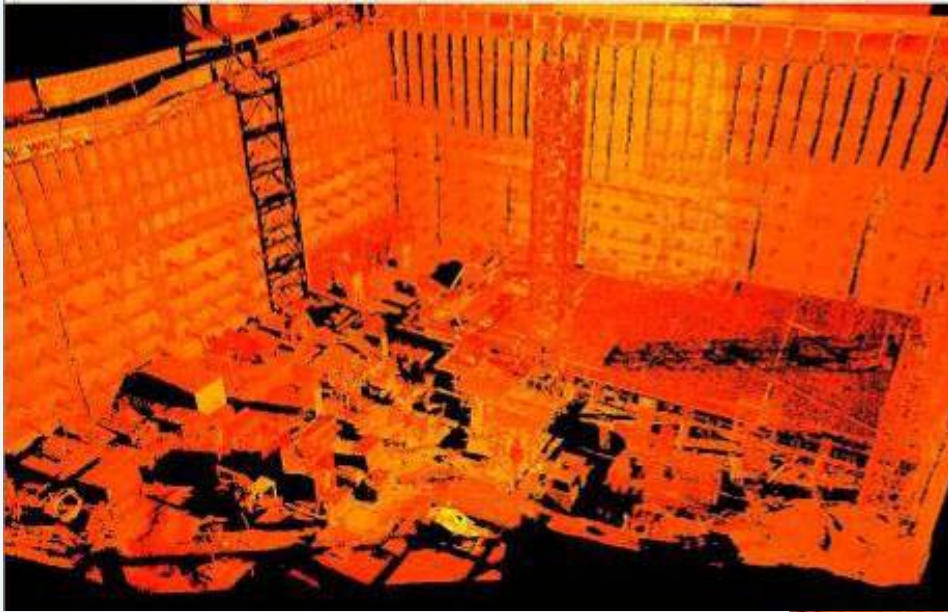

Building foundations
captured in under
an hour on site

Progress snapshots
captured periodically

Individual rock bolts
easily identified and
coordinated to within
5mm

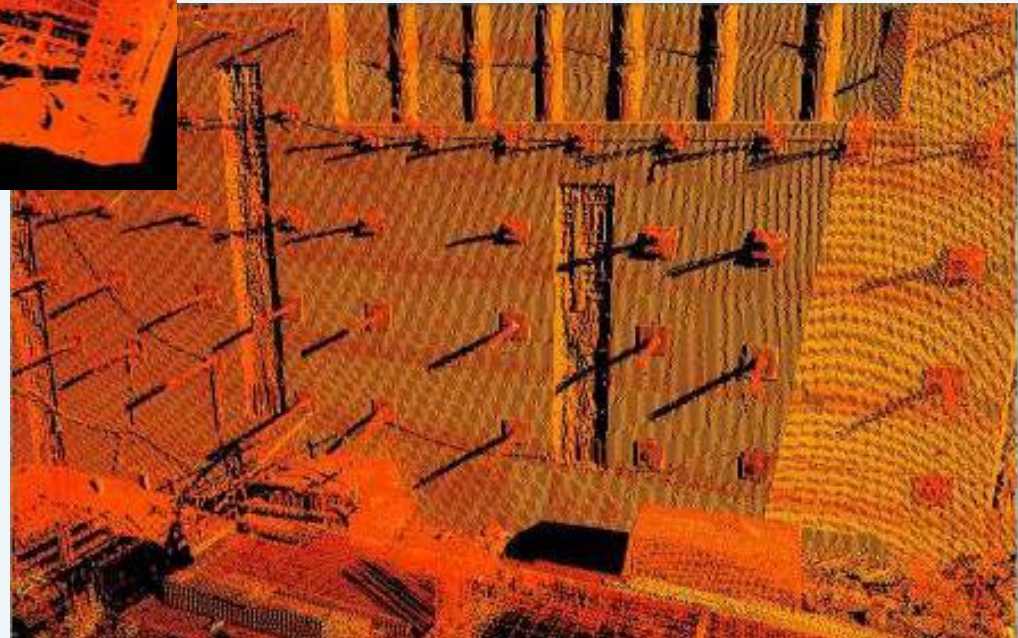

Detail Surveys

- Industry Standard Deliverables
- Above ground features captured
- Contourable data
- Structural features captured

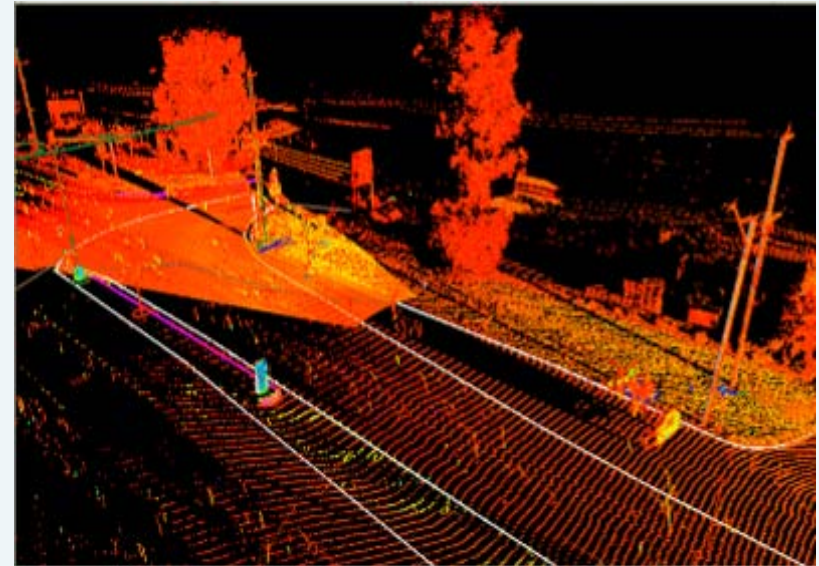
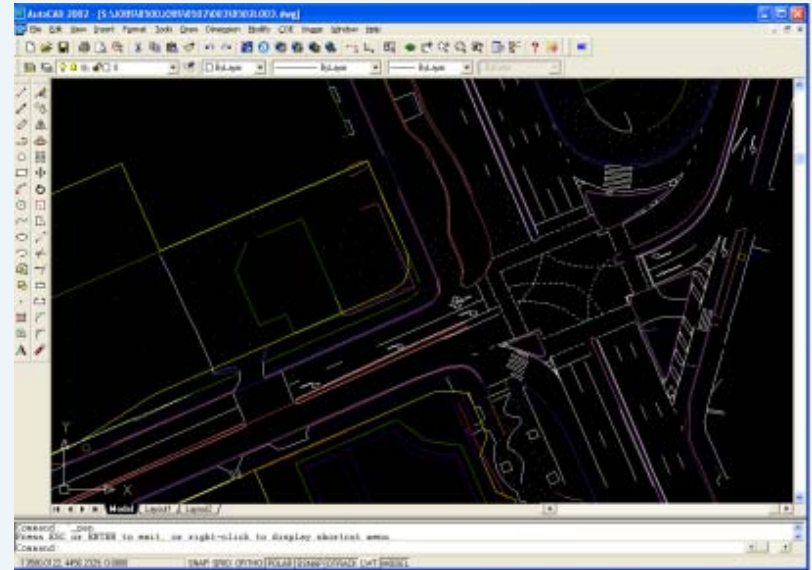
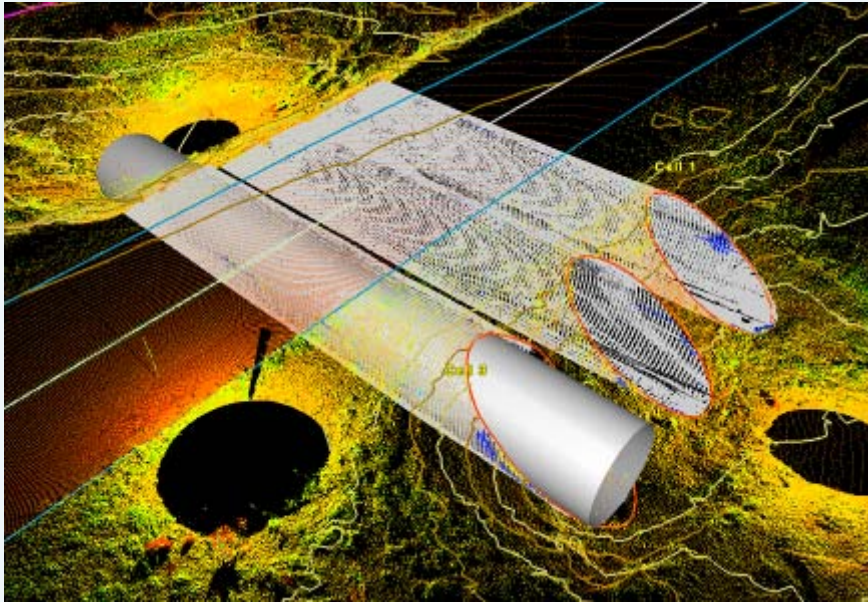

Marine Analysis

Sections or mesh outputs enable hydro analysis of the hull

Successful design reproductions

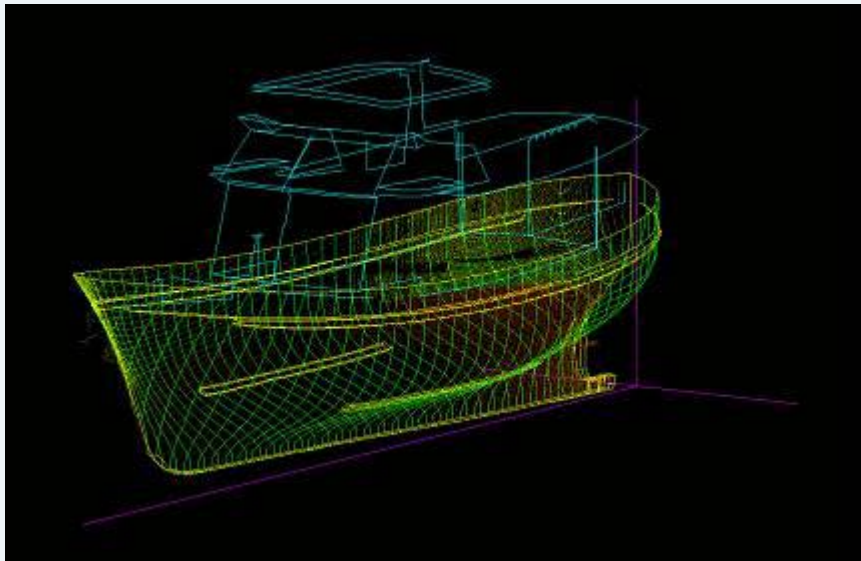

Structural Analysis

Section or point outputs enable comparison to design or similar structure

See deformation presentation for more information

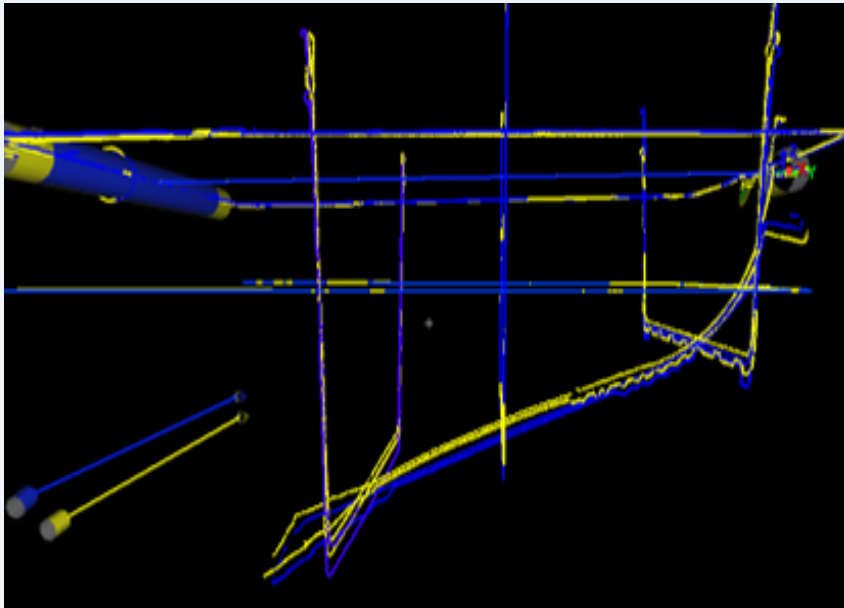
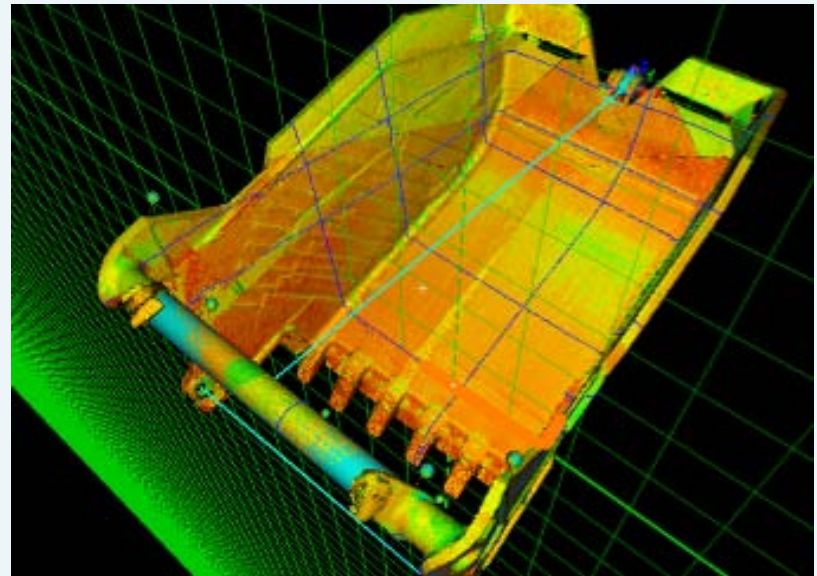
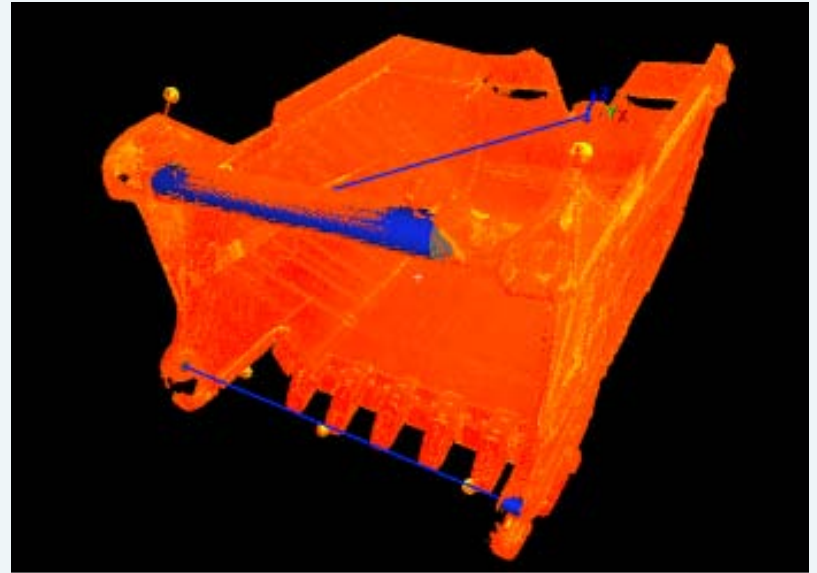

Deliverables

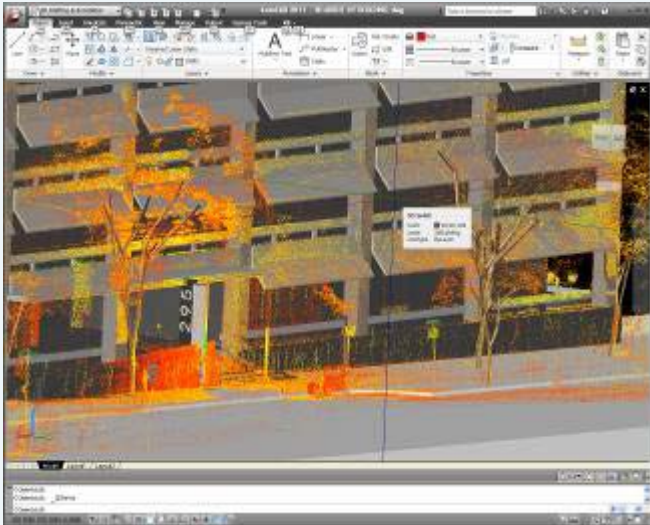

- Cyclone software is the base scanning software that allows complex modelling capabilities and clash detection. It is traditionally used to capture and register the scans into a combined modelspace by surveyors
- Truview is a free scanning viewing software package which allows you to view each scan from the perspective of the scanner. It allows simple measurements to be made and with the use of XMLs is a very powerful communication tool.
- AutoCAD 2011 is now supporting point cloud data as a standard function can import up to 2 billion points. 3d data users will be able to manipulate the point cloud using standard 3d commands. Add on packages such as Cloudworx or Kubit will increase the functionality with better scan management, modelling of cylinders and planes and clash detection.
- Final modelled objects and coded strings may be exported into standard engineering packages such as AutoDESK, Microstation, 12d, Moss etc.
- PDF writer allows capture of scan data and 3D models that is measurable with the full version. The 3d projects can be viewed freely with recent version of PDF reader.

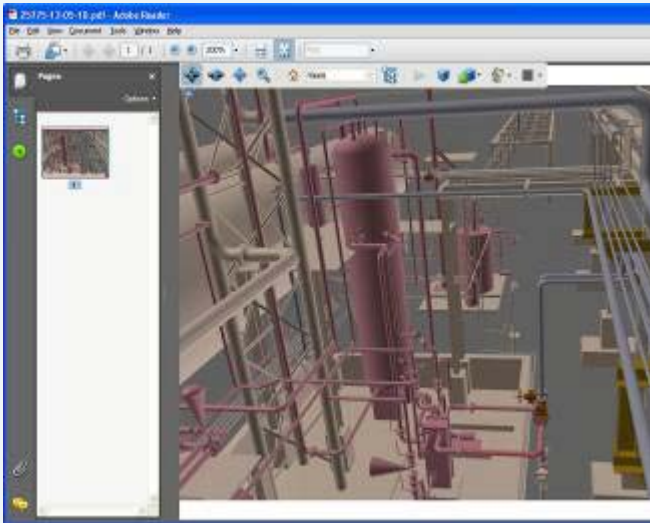

Creating Exceptional Value

Offices	Telephone
Brisbane	61 7 3354 9700
Sunshine Coast	61 7 5470 6099
Gladstone	61 7 4972 9120
Agnes Water	61 7 4974 9755
Weipa	61 7 4069 9414

www.northgroup.com.au

